



Bhaktamar RESIDENCY

2 BHK PREMIUM APARTMENTS & COMMERCIAL SPACES
KALYANI NAGAR ANNEX (WADGAON SHERI)

Commercial Block

GROUND FLOOR PLAN

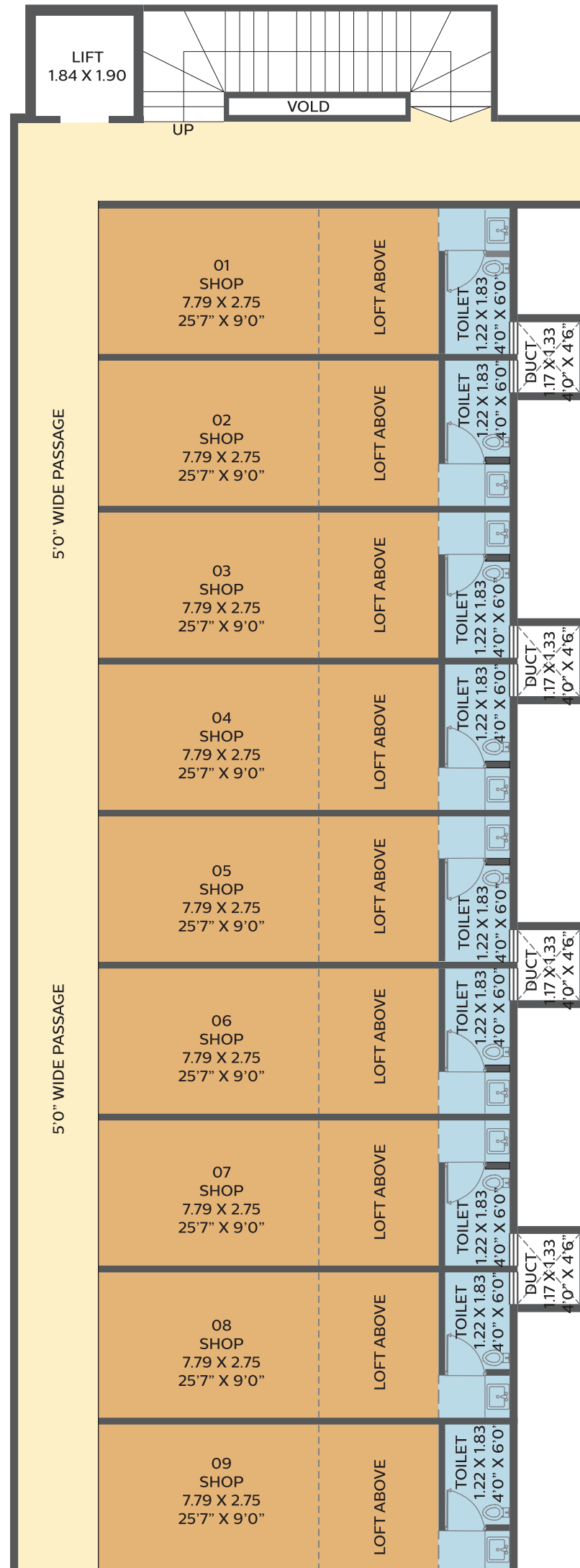

Note: Shop No 9th as proposed



CREDAI
PUNE METRO

P52100022186
<https://maharera.mahaonline.gov.in/>

RERA STATEMENT

SHOP NO.	TYPES	CARPET AREA (sq.m)	LOFT AREA (sq.m)	DRY BALCONY (sq.m)	TERRACE AREA (sq.m)	GARDEN TERRACE AREA (sq.m)	TOTAL AREA (sq.m)
01, 02, 03, 04, 05, 06, 07, 08 & 09	SHOP	21.46	10.77	0.00	0.00	0.00	32.23

A PROJECT BY



Bhaktamar
REALITIES LLP
LLP NO. - AAD 1770



Bhaktamar RESIDENCY

2 BHK PREMIUM APARTMENTS & COMMERCIAL SPACES
KALYANI NAGAR ANNEX (WADGAON SHERI)

Commercial Block

1st FLOOR PLAN

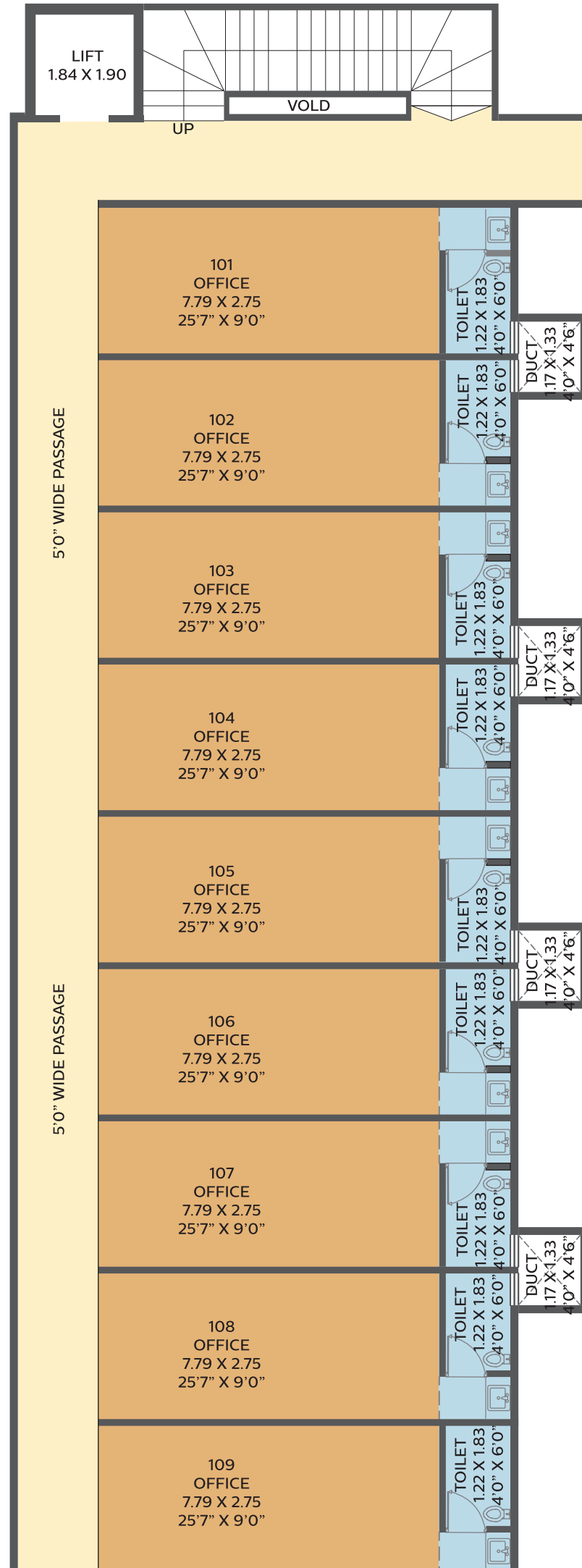

Note: Office No 108 & 109 as proposed



CREDAI
PUNE METRO

P52100022186
<https://maharera.mahaonline.gov.in/>

RERA STATEMENT

OFFICE NO.	TYPES	CARPET AREA (sq.m)	LOFT AREA (sq.m)	DRY BALCONY (sq.m)	TERRACE AREA (sq.m)	GARDEN TERRACE AREA (sq.m)	TOTAL AREA (sq.m)
101, 102, 103, 104, 105, 106, 107, 108 & 109	OFFICES	21.46	0.00	0.00	0.00	0.00	21.46

A PROJECT BY



Bhaktamar
REALITIES LLP
LLP NO. -AAD 1770